



Lower Towamensing Township

595 Hahns Dairy Road • Palmerton, PA 18071 • Phone: (610) 826-2522 • Fax: (610) 826-2585

Application for Township Road Occupancy

The Lower Towamensing Township Zoning Ordinance requires all driveways comply with the following:

1. Driveways shall be located at least 40' from the intersection of any street.
2. Driveways shall be a minimum of 10' and a maximum of 20' feet in width.
3. Driveways serving single family dwellings shall be a minimum of 5' from any side lot line; exception shared driveways.
4. Driveways shall be constructed in such a manner so as not to create a drainage problem on an adjacent property or street.
5. Driveways shall be so constructed and maintained that the materials of which the driveways are made will not wash or be deposited upon public roads.
6. The first 50' of the Driveway shall be paved within 1 year.

Application is hereby made by _____ (print name), to install a driveway along _____ (road/street) as follows:

(Detailed Description of Work)

Approximate date when work will be started: _____

Approximate date when work will be completed: _____

Distance from center line of roadway to gutter or ditch: _____ Ft.

Distance from center line of roadway to right-of-way line: _____ Ft.

In accordance with the accompanying sketch, and under and subject to all the conditions, restrictions and regulations prescribed by the Driveway Ordinance of Lower Towamensing Township, with the same force and effect as if written or printed herein, and under and subject to such special conditions, restrictions and regulations that may be imposed by the Board of Supervisors.

Signature of Applicant: _____

Address of Applicant: _____

Phone # / Email: _____

_____(Official Use Only)_____

Date: _____

Approved: _____

Denied: _____

Fee: _____

Zoning Officer

Payment of fee does not guarantee issuance of permit. Fees are nonrefundable.



APPLICATION FOR MINIMUM USE DRIVEWAY

A Minimum Use Driveway Is A Residential Or Other Driveway

Which Is Expected To Be Used By Not More Than 25 Vehicles Per Day (i.e. 50 A.D.T.)

SEE PUBLICATION 312 GUIDE

FOR DEPT. USE

APPLICANT/PROPERTY OWNER		
ADDRESS		
POST OFFICE	ZIP CODE	FEE
PHONE	EMAIL*	CHECK NO.
<input type="checkbox"/> CHECK THIS BOX IF PAYING BY CREDIT CARD. A valid email address is required. Applicant will receive an invoice by email for payment by credit card prior to issuance of the Permit.		

APPL. NO.

LOCATION OF PROPOSED DRIVEWAY

County _____

Municipality _____

Route No. _____

Name of Nearest Intersection _____

Distance to Nearest Intersection in Feet _____

*If a valid email address is provided, the driveway permit will be sent via email; otherwise it will be sent via standard US mail.

APPLICATION IS MADE TO

CONSTRUCT A NEW DRIVEWAY ALTER AN EXISTING DRIVEWAY

DATE WORK SCHEDULED TO BEGIN _____

DATE WORK SCHEDULED TO BE COMPLETED _____

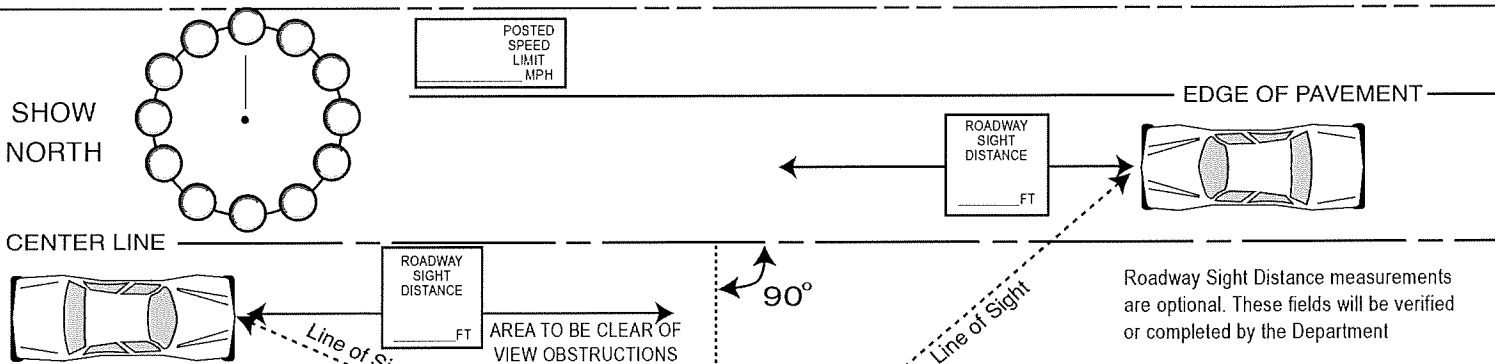

Roadway Sight Distance measurements are optional. These fields will be verified or completed by the Department

EDGE OF TRAVEL LANE — RADIUS (R) OF BOTH DRIVEWAY CURVES MUST BE AT LEAST FIVE FEET FOR CARS

FOR DEPARTMENT USE ONLY

Application Received By _____ Date _____

Notes:

FOR DEPARTMENT USE ONLY

Site Reviewed On _____

Comments

ROADWAY SHOULDER (Fill in appropriate line) SLOPE (Fill in appropriate slope)

Description _____ S.R. _____ Segment _____ Offset _____

Field Viewed By _____ SIGNATURE _____ DATE _____

Is any portion of the property reserved for a person with a disability or a severely disabled veteran? YES NO

Under and subject to all the conditions, restrictions and regulations prescribed by the Pennsylvania Department of Transportation and on the issued Permit, Form M-945P.

The applicant certifies that all statements contained herein are true and correct.

By **X** _____ SIGNATURE(S) _____ DATE _____

§ 450-113 Driveways.

- A. Driveway entrances or exits shall be located a minimum of 40 feet from the intersection of any street.
- B. No entrance or exit for a driveway serving single-family dwellings shall be less than 10 feet or more than 20 feet in width, excluding radii.
- C. No driveway shall be located within five feet of any side lot line, except in the case of common or shared driveways as follows:
 - (1) Common or shared driveways are only permitted when a recorded maintenance agreement is in place.
 - (2) Common or shared driveways can serve no more than three lots.
- D. Adequate provisions shall be made to maintain uninterrupted parallel drainage along a street at the point of access drive entry. The Township may require an applicant to install an appropriate type and size of pipe at a driveway crossing.
- E. Driveways shall be maintained so that materials of which the driveways are made will not wash or be deposited into streets.
- F. Driveways shall be paved with bituminous paving for a minimum distance of 50 feet from the edge of shoulder of the intersecting street. This surfacing must be completed within one year of installation of the driveway.
- G. Driveways shall be installed according to the following profile detail:

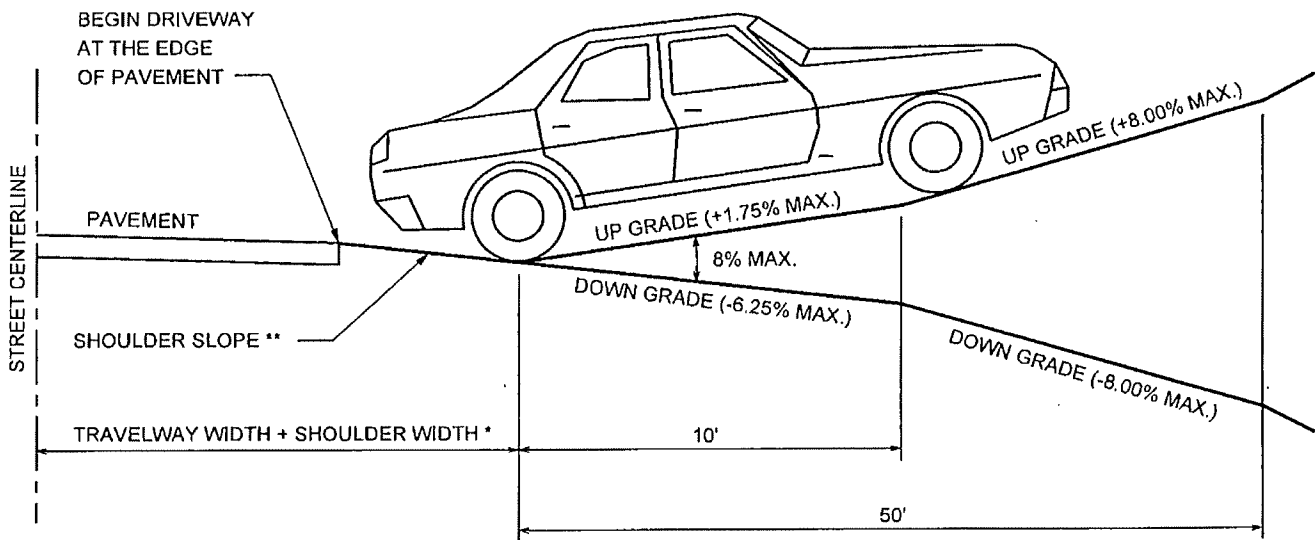

* TOTAL DISTANCE SHALL BE DETERMINED FROM THE REQUIRED AMOUNTS FOR THE APPROPRIATE STREET DESIGNATION

** 3/4" PER FOOT DOWN GRADE (-6.25%)

NOTE: THIS DETAIL HAS BEEN MODIFIED FROM FIGURE 1 OF PA CODE TITLE 67, TRANSPORTATION, CHAPTER 441. "ACCESS TO AND OCCUPANCY OF HIGHWAYS BY DRIVEWAYS AND LOCAL ROADS", SECTION 441.8.(i)